



Wired Wall Mount Terminal

Touchscreen Terminal for OmniLogic

Owner's Manual

Contents

| | |
|--------------------|---|
| Description..... | 2 |
| Installation..... | 3 |
| Configuration..... | 6 |
| Operation..... | 6 |

HLWALLMOUNT

**REGISTER
NOW**

to extend your
WARRANTY

see back of manual for details

Hayward Industries
400 Connell Drive, Suite 6100
Berkeley Heights, NJ 07922
Phone: (908) 355-7995
www.hayward.com



HAYWARD®

FCC Statement

This device complies with part 15 of the FCC rules. Operation is subject to the following two conditions: (1) This device may not cause harmful interference, and (2) this device must accept any interference received, including interference that may cause undesired operation.

Changes or modifications not expressly approved by Hayward could void the user's authority to operate this equipment.

NOTE: This equipment has been tested and found to comply with the limits for a Class B digital device, pursuant to Part 15 of the FCC Rules. These limits are designed to provide reasonable protection against harmful interference in a residential installation. This equipment generates, uses and can radiate radio frequency energy and, if not installed and used in accordance with the instructions, may cause harmful interference to radio communications. However, there is no guarantee that interference will not occur in a particular installation. If this equipment does cause harmful interference to radio or television reception, which can be determined by turning the equipment off and on, the user is encouraged to try to correct the interference by one or more of the following measures:

- Reorient or relocate the receiving antenna.
- Increase the separation between the equipment and receiver.
- Connect the equipment into an outlet on a circuit different from that to which the receiver is connected.
- Consult the dealer or an experienced radio / TV technician for help.

Industry Canada Statement

This Class B digital apparatus complies with Canadian ICES-003.

Cet appareil numérique de la classe B est conforme à la norme NMB-003 du Canada.

The term "IC" before the certification / registration number only signifies that the Industry Canada technical specifications were met.



Description

The HLWALLMOUNT is a remote touchscreen terminal that wires directly to the OmniLogic pool automation controller. It is designed to fasten to a wall giving the user convenient access for monitoring and controlling their pool. No more than one HLWALLMOUNT can be installed and connected to an OmniLogic. After installation, the OmniLogic will detect the new HLWALLMOUNT and automatically configure itself to utilize the new terminal.

Compatibility

The HLWALLMOUNT is compatible with all OmniLogic pool controls.

Before You Begin

Included:

- HLWALLMOUNT Remote Terminal

What you'll need:

- mounting screws/anchors
- an appropriate length of 4 conductor, 20 - 24AWG twisted pair wire (CAT3 or better preferred but not mandatory) for connecting the HLWALLMOUNT to the OmniLogic
- wirecutter/wirestripper
- tools for mounting, small flathead screwdriver for screw terminals

The HLWALLMOUNT must be mounted indoors or in a weather protected area (rain should never be in contact with the touchscreen).

When considering a potential mounting location, survey the wiring route from the OmniLogic to the HLWALLMOUNT. Ensure that you can successfully run an uninterrupted length of 4 conductor wire. Although various types of wire can be used, 4 conductor, solid 22AWG phone cable is recommended. Refer to the table below for limitations on wire run lengths. Connections from the HLWALLMOUNT to the OmniLogic must not exceed the recommended lengths shown in the table below.

| | 20 AWG | 22AWG | 24AWG |
|-------------------------|---------------|--------------|--------------|
| Maximum Distance | 350ft / 107m | 285ft / 85m | 180ft / 55m |



HAYWARD®

Update MSP Firmware

Because the firmware version of the HLWALLMOUNT terminal must always match the OmniLogic MSP, both must be updated to the latest available version. To update the MSP, follow the firmware upgrade procedure described in the OmniLogic Operation Manual.

Installation

DANGER of Death, Injury or Property Damage if procedure not followed. This accessory connects to the OmniLogic panel beneath the dead front. Dead front removal is required for this installation. Power to the OmniLogic panel **MUST** be shut off before the dead front is removed. This means a complete shutdown of power to the entire OmniLogic panel.

Remove power to the OmniLogic. Remove the OmniLogic cover panel (dead front) to expose the main board and internal relays.

Mounting

1. Remove the remote terminal wallplate from the cover by inserting a screwdriver in the slot shown below. Lift up on the cover while pushing gently with the screwdriver.

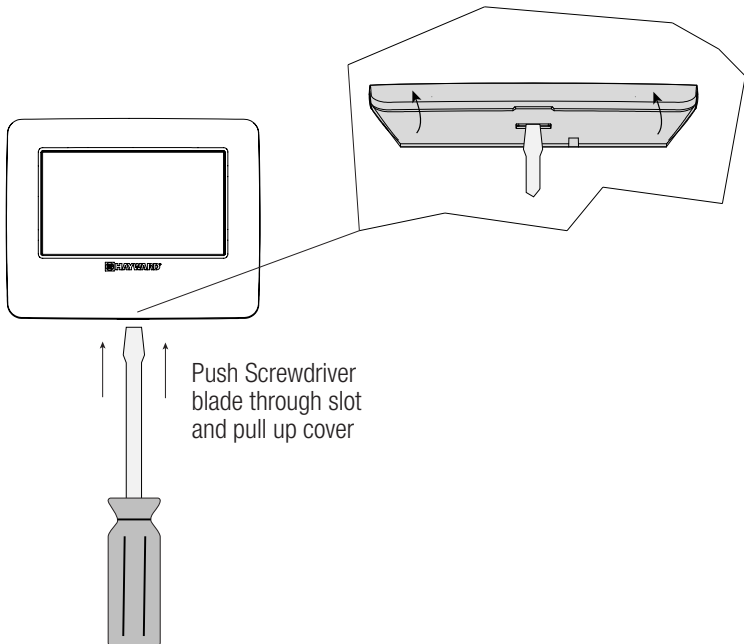



HAYWARD®

2. Fasten the wall plate at the desired location (screws supplied by installer).

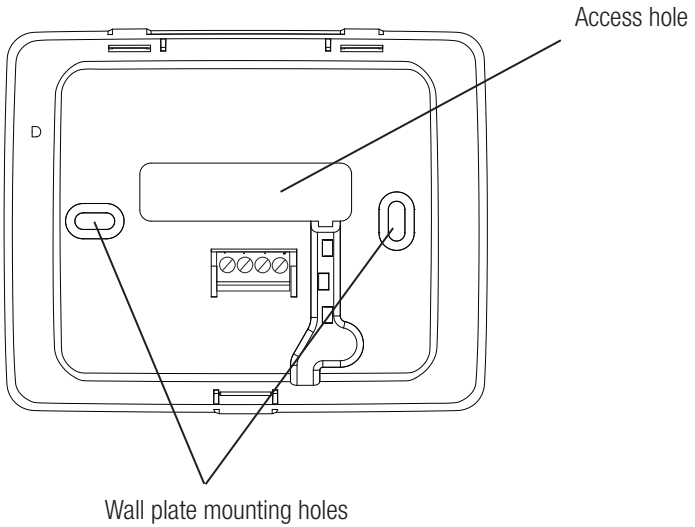

Wiring

Use four conductor cable (typically phone cable) to connect the remote display keypad with the OmniLogic Main Board. Refer to the table on page 2 for maximum wire length.

For a clean "cable free" look, route the cable so that it exits the mounting surface and enters through the access hole in the wall plate.



HAYWARD®

Connect the cable to the high speed RS-485 screw terminals on the OmniLogic and HLWALL-MOUNT as shown below. The screw terminals are numbered on both units. Connect 1 to 1, 2 to 2, etc. Screw terminal #5 is not used on the OmniLogic. Refer to the diagram below.

After wiring is complete, reinstall the HLWALLMOUNT cover. Reinstall the OmniLogic dead front and restore power to the OmniLogic.

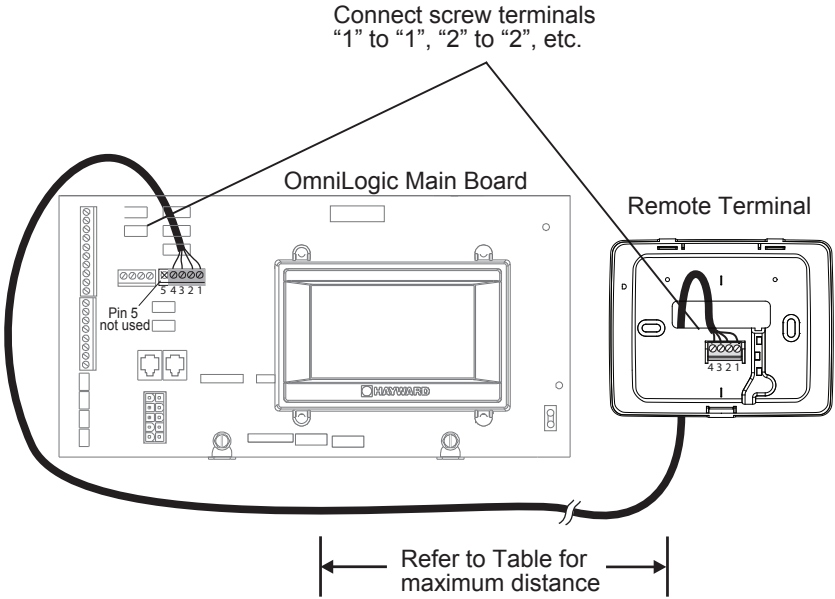

Configuration

When the OmniLogic first starts, the HLWALLMOUNT should automatically be discovered and configured. No input is required from the user. To verify that the OmniLogic has discovered the HLWALLMOUNT, go to the local terminal (touchscreen on the OmniLogic) and follow the procedure below. There should be a line entry showing the HUA and version.

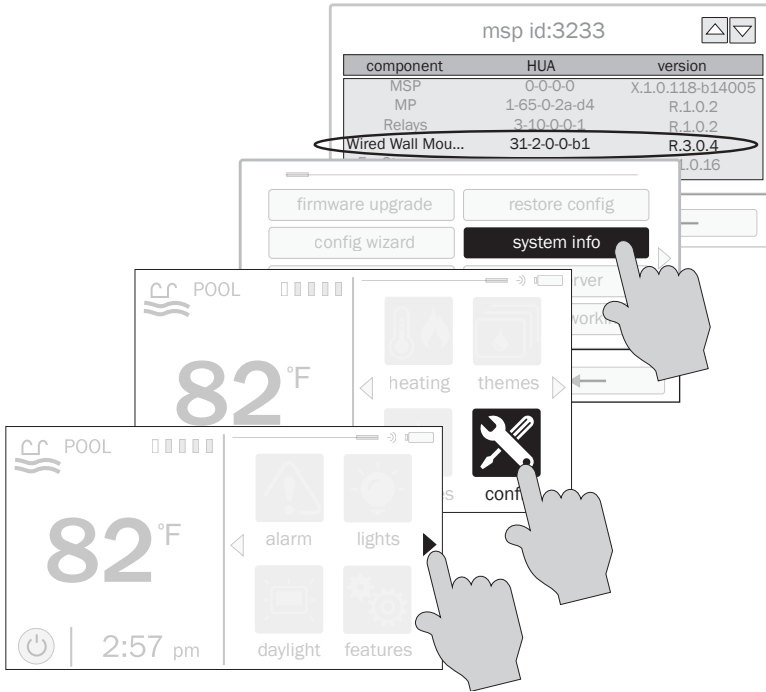

Operation

The HLWALLMOUNT provides the same functionality as the Local Terminal except for the following:

- No Service Mode - Service mode is only accessible from the Local Terminal
- Limited Configuration options - Full access to all OmniLogic configuration settings is only available at the Local Terminal.

90 DAY EXTENDED WARRANTY* REGISTER WITH YOUR SMARTPHONE

— PROTECT YOUR INVESTMENT IN 2 EASY STEPS —

1. TAKE A PHOTO

Take a photo of the camera icon



2. SEND IT IN

Send it in using **one** of the methods below



SMARTPHONE

Text a photo of the camera icon to **71403**

OR



ONLINE

Visit Hayward.com/Warranty

OR



MESSENGER

Send photo to **photoregister**

*Extended warranty is in addition to applicable product warranty and is for parts only, labor not included.

Need help? Visit photoregister.com/help or text HELP to 71403.

For further information or consumer
technical support, visit our website at
www.hayward.com



HAYWARD®



Hayward is a registered trademark and OmniLogic is a trademark of Hayward Industries, Inc. © 2020 Hayward Industries, Inc.

All other trademarks not owned by Hayward are the property of their respective owners. Hayward is not in any way affiliated with or endorsed by those third parties.

USE ONLY HAYWARD GENUINE REPLACEMENT PARTS